

SP25M compact scanning probe system

The world's most compact and versatile scanning system

The SP25M is two sensors in one, and has unrivalled flexibility due to the system's modularity. Users can scan for form, position, and size but also take high accuracy discrete points by using a dedicated scanning module or, alternatively, use an adaptor to carry Renishaw's TP20 range of touch-trigger probe modules.

The SP25M's compact size and autojoint mounting makes it compatible with PH10M, PH10MQ and PH6M probe heads. It can also be mounted on an extension bar, providing excellent reach and access to part features.

Four scanning modules feature a pivoting design which delivers exceptional dynamic performance and optimised high accuracy performance over the entire stylus range from 20 to 400 mm effective working length (EWL). This avoids most of the performance loss seen in other scanning probes as stylus length increases.

Module and stylus changing is enabled using the FCR25 flexible change rack, which can be located either on the CMM bed, or in Renishaw's MRS modular rack system.

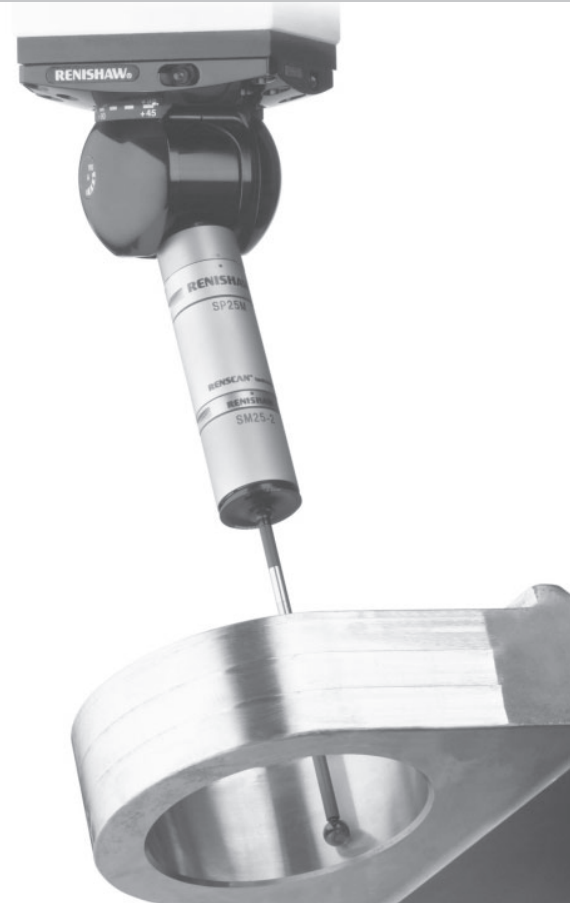

Key benefits

Excellent part accessibility

At just 25 mm (0.97 in) diameter, the SP25M is small and light, making it ideally suited to mounting on articulating heads and on extensions of up to 100 mm (3.94 in). Thus a total reach of some 600 mm (23.62 in) is possible. However, it is also sufficiently compact to suit very small CMMs and multi-sensor machines.

Modularity to allow unrivalled flexibility

The SP25M system allows the user to configure a basic installation which can be readily expanded at any time. This can include any, or all, system elements, plus automated rack changing for optimum productivity.

Two sensors in one - scanning and touch-trigger

SP25M allows the user to always select the most suitable measurement solution to match the application, either scanning or touch-trigger. Now you can efficiently do both with a single probe system!

Innovations

Isolated optical metrology

A pivoting mechanism and isolated optical metrology system directly measures each axis of probe deflection. This avoids errors generated in stacked measurement axes, as used in 'tower' scanning probes.

Four scanning modules provide optimal performance across a range of stylus lengths

Each scanning module has a spring rate and gain optimised for a range of stylus lengths. SP25M measures accurately with styli up to 400 mm (15.74 in) long. This breakthrough technology puts SP25M into a class of its own.

3rd order polynomial calibration

Renishaw has developed sophisticated calibration methods for its range of scanning probes to ensure maximised performance. SP25M uses the most advanced of these methods.

Mounting	Renishaw's autojoint: PH10M, PH10MQ or PH6 heads and may be mounted on ≤100 mm autojoint extension bars
Probe dimensions	Ø25 mm (Ø0.98 in) x length dependent upon module used
Probe attributes	3 axis analogue measurement (X, Y, Z). Pivoting motion in XY plane with translation in Z
Measurement range	±0.5 mm (±0.02 in) deflection in all directions in all orientations
Overtravel range	±X, ±Y = 2.0 mm (0.08 in) +Z = 1.7 mm (0.07 in) -Z = 1.2 mm (0.05 in)
Crash protection	X, Y, -Z via break-off of either module or stylus holder +Z via integral bump-stop design
Resolution	<0.1 µm (0.000004 in) with either UCC1/UCC2 controller or AC3 interface card
Spring rate	~0.2 N/mm (with longest stylus) ~0.6 N/mm (with shortest stylus)
Damping	Single viscous fluid damper
Power supply	+12 V (±5%), -12 V (+10% / -8%), +5 V (+10% / +13%) DC at probe
Outputs (X, Y, Z)	Non-linear and non-orthogonal analogue outputs – rate, gain and resolution are not fixed
Probe calibration	SP25M requires a non-linear, third-order polynomial calibration method
Suitable styli	M3 range
Stylus length (EWL)	SM25-1 20 - 50 mm (0.78 - 1.97 in) using 20 mm - 50 mm stylus SM25-2 50 - 105 mm (1.97 - 4.11 in) using 20 mm - 75 mm stylus SM25-3 120 - 200 mm (4.72 - 7.87 in) using 20 mm - 100 mm stylus SM25-4 220 - 400 mm (8.66 - 15.75 in) using 20 mm - 200 mm stylus
Interface options	UCC2, UCC1 with SP25M daughtercard, or, AC3 PC interface card for machines not fitted with the UCC1/UCC2 controller

Additional information

A range of SP25M probe kits is available to suit your application - from entry-level kits for touch-trigger users, to full combination kits. A range of module kits are available to supplement the probe kits, allowing SP25M users to build up their probing capability over time.

Details of probe and module kits, module change racks and spare parts can be found at www.renishaw.com/SP25M.

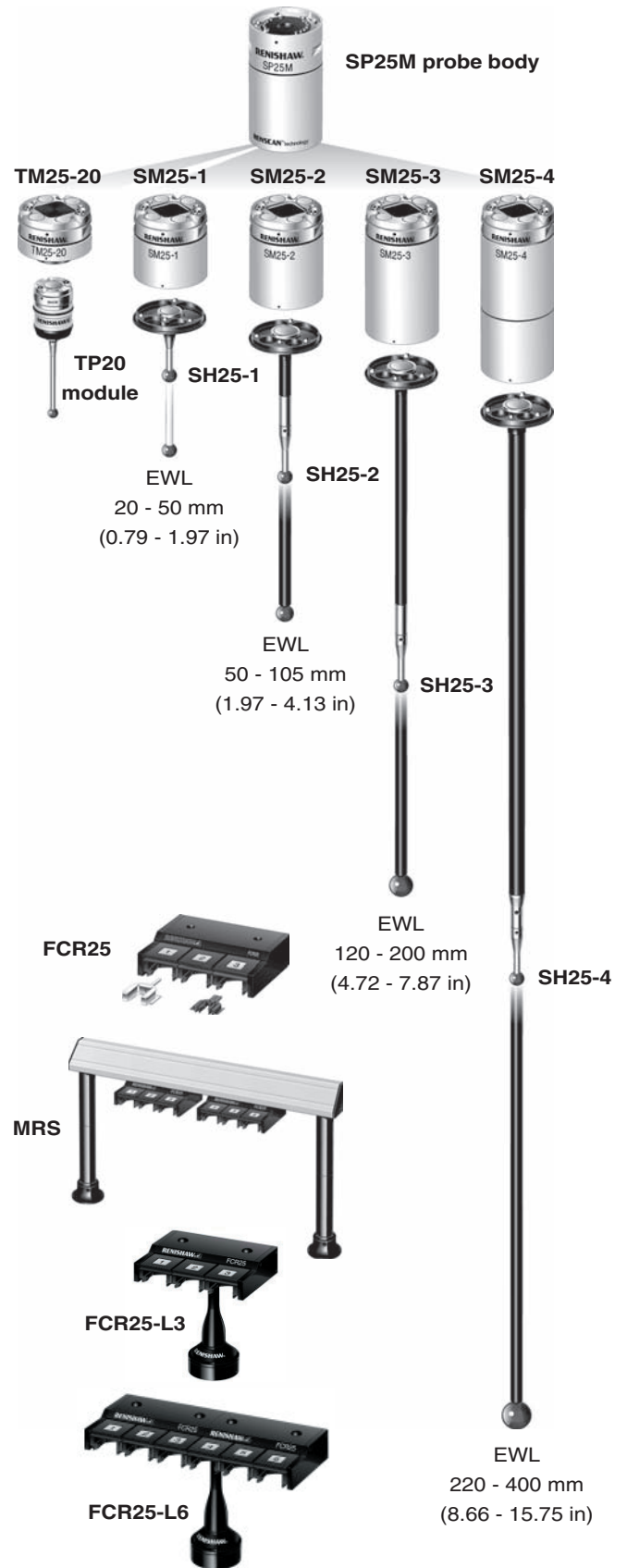

For worldwide contact details, please visit our main website at www.renishaw.com/contact